

TECHNICAL SPECIFICATIONS

GB5BW Series

Air Handler

**13 SEER Residential or
Multi-family System
18,000 - 30,000 Btuh (Heat Pump
& Air Conditioner)**

The GB5BW Series air handler, when combined with our heat pump or air conditioner, offers a full line of quality, split system heating and cooling equipment.



Shown in Bottom
Return Application

WARRANTY

- This product carries a 5-year all parts warranty. When installed with a matched outdoor unit, the air handler will carry the outdoor system warranty. See current warranty document or visit our consumer web site for warranty details.

FEATURES and BENEFITS

- **Durable, Attractive Cabinet:** Designed using galvanized steel with optional white decorative panel. The plastic drain pan is corrosion resistant.
- **Multi-speed:** Gives flexibility of installation.
- **Blower Control Board:** Incorporating blower time delay.
- **Ease-of-Service:** Plug-in wire connections and built-in filter rack makes the air handler easy to service.
- **Heater Kits Installed:** Available in 5kw, 8kw & 10kw.
- **Breaker Accessibility:** Breaker accessible from front of unit.
- **Fully insulated Cabinet:** for quiet operation.
- **Front and/or Bottom Return air**
- **Offset Hanging Bracket for Easy Installation**
- **Energy Efficient Motor:** Provides greater efficiency for 13 SEER applications.

DIMENSIONS

Model Number GB5BW-	Refrigerant Connections		Filter Size	Supply Air Duct Dimension	A	B	C
	Suction Dia.	Liquid Dia.					
018	3/4	3/8	16 x 20 x 1	9 x 17 1/4	36 3/8	15	9 1/2
024	3/4	3/8	16 x 20 x 1	9 x 17 1/4	36 3/8	15	9 1/2
030	3/4	3/8	20 x 20 x 1	9 x 17 1/4	43 1/2	21	9 1/2

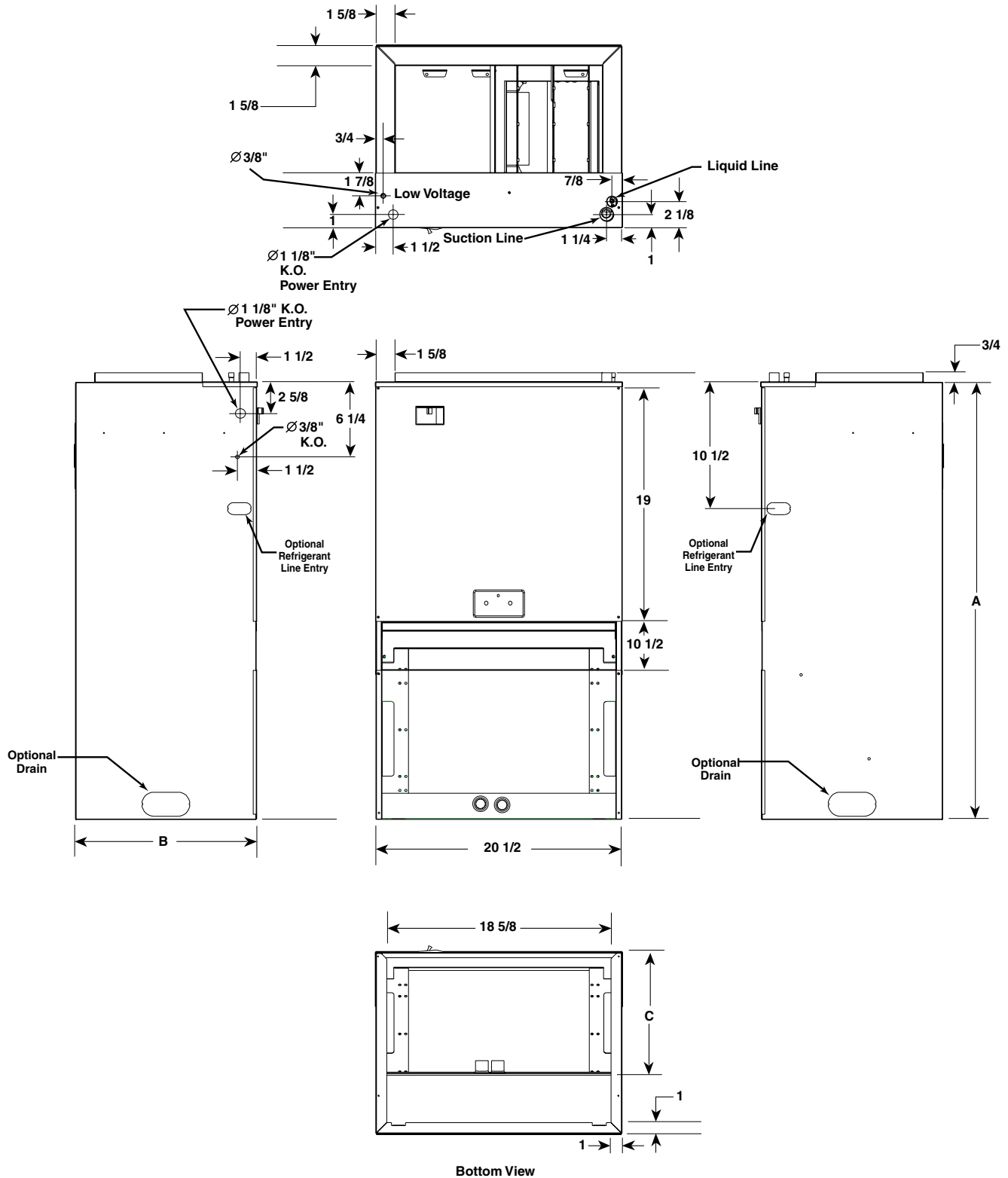

SPECIFICATIONS

Model Number GB5BW-	018/024	030
Nominal Cooling Capacity - Btuh (1)	23,000	27,000
Refrigerant Flow Control (2)	Orifice	Orifice
Available Heat (kw)	5, 8, 10	5, 8, 10
Nominal Blower Size (D x W)	10 x 6	10 x 6
(H.P. - Speed - Type)	1/2-5-BDC	1/2-5-BDC
Rated External Static Pressure (in. W.C.)	.30	.30
CFM @ Rated ESP	900	900
Filter Size (see note below)	16 x 20 x 1	20 x 20 x 1
Approximate Shipping Weight (lbs.)	80	88

(1) See current ARI Directory for certified combinations and ratings.

(2) Units are 13 SEER air conditioner ready for 024 matches shipped.

The 024 unit has 2-ton orifice factory installed.

The 030 unit has 3-ton orifice factory installed.

SYSTEM AIR FLOW DATA

		Dry Coil ESP	0.10	0.20	0.30	0.40	0.50	0.60	0.70	0.80
018K/024K	Low		640	597	553	529	492	452	428	388
	Med-Low		721	691	652	624	584	554	528	487
	Medium		830	795	760	737	702	666	649	613
	Med-High		929	906	881	844	817	771	718	663
	High		1074	1018	975	925	868	811	753	694

		Dry Coil ESP	0.10	0.20	0.30	0.40	0.50	0.60	0.70	0.80
030K	Low		596	568	525	481	450	401	357	331
	Med-Low		689	652	614	587	546	505	474	433
	Medium		786	746	706	675	629	597	561	530
	Med-High		885	862	830	804	770	736	709	658
	High		1153	1110	1061	1011	956	902	837	763

Notes:

- 1) Airflow is shown in cfm, +/- 5%.
- 2) External static pressure is shown in inches w.c.
- 3) All airflows are measured with filter and with dry coil. For wet coil, subtract .1" external static pressure.
- 4) See unit nameplate or installation instructions for maximum recommended external static pressure.

ELECTRICAL DATA

Model Number GB5BW-	018-05, 024-05, 030-05		024-08, 030-08		024-10, 030-10	
Voltage	208	240	208	240	208	240
KW (nominal)	3.8	5	6	8	7.5	10
Minimum Circuit Ampacity Single Circuit	26.8	30.0	38.8	44.2	48.4	55.1
Maximum Over-Current Protection Single Circuit	30	30	40	50	50	60

MODEL IDENTIFICATION CODE

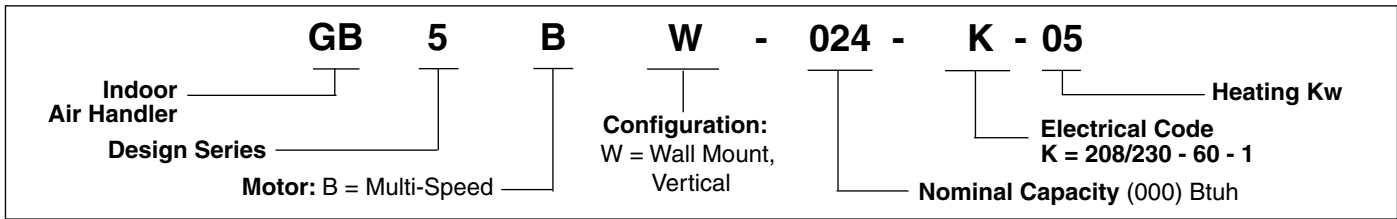

RATING MATRIX: AC R-22

OUTDOOR UNIT MODEL NUMBER (CONDENSING UNIT) *S5BD	INDOOR UNIT MODEL NUMBER (AIR HANDLER) GB5BW-	COOLING CAPACITY @ 95 ° F (BTUH)	SEER	INDOOR ORIFICE
018KA	024K	17,100	13.00	.053
024KA/B	024K	22,200	13.00	.061
024KA/B	030K	23,000	13.50	.061
030KA/B	030K	27,000	13.00	.067

RATING MATRIX: HP R-22

OUTDOOR UNIT MODEL NUMBER (CONDENSING UNIT) *T5BD	INDOOR UNIT MODEL NUMBER (AIR HANDLER) GB5BW-	COOLING CAPACITY @ 95 ° F (BTUH)	SEER	HEATING CAPACITY @ 47 ° F (BTUH)	HSPF	INDOOR ORIFICE
018K	018K	18,000	13.00	16,000	7.7	.053
024K	024K	23,600	13.00	21,800	7.7	.061
030K	030K	27,400	13.00	27,400	7.7	.067

RATING MATRIX: AC R-410A

OUTDOOR UNIT MODEL NUMBER (CONDENSING UNIT) *S4BD	INDOOR UNIT MODEL NUMBER (AIR HANDLER) GB5BW-	COOLING CAPACITY @ 95 ° F (BTUH)	SEER	INDOOR ORIFICE
018KA	030K	18,000	13.00	.050
024KA	030K	23,400	13.00	.057
030KA	030K	26,600	13.00	.063

RATING MATRIX: HP R-410A

OUTDOOR UNIT MODEL NUMBER (CONDENSING UNIT) *T4BD	INDOOR UNIT MODEL NUMBER (AIR HANDLER) GB5BW-	COOLING CAPACITY @ 95 ° F (BTUH)	SEER	HEATING CAPACITY @ 47 ° F (BTUH)	HSPF	INDOOR ORIFICE
018K	024K	18,000	13.00	16,000	8.0	.050
018K	030K	18,600	13.00	17,800	7.7	.050
024K/KA	024K	23,600	13.00	21,800	7.7	.057
024K/KA	030K	22,600	13.00	23,000	7.7	.057
030K/KA	030K	27,400	13.00	29,000	7.7	.065

- ACCESSORIES**
- Decorative Louvered Panel - 903892 for 018/024
 - Decorative Louvered Panel - 919583 for 030

NOTE: See Current ARI Directory for certified combinations and ratings.



GENERAL TERMS OF LIMITED WARRANTY

NORDYNE will furnish a replacement for any part of this product which fails in normal use and service within the first five years of installation, in accordance with the terms of the warranty.

For complete details of the Limited Warranty, including applicable terms and conditions, see your local installer or contact the NORDYNE warranty department for a copy.

NORDYNE

COMPLETE COMFORT. GENUINE VALUE. 8000 Phoenix Parkway | O'Fallon, MO 63368-3827

Specifications and illustrations subject to change without notice and without incurring obligations. Printed in U.S.A (12/2012)

341C-1212 (Replaces 341C-1112)